

PSL classic

Instructions for use



Keeler

Next ▶

Contents

1. Introduction
2. Symbols
3. Indications for use
4. Intended use / purpose of instrument
5. Brief description of the instrument
6. Safety
7. Cleaning and disinfection instructions
8. Transport, storage and working conditions
9. Warnings and cautions
10. Names of controls and components
11. Instructions for use
 - Preparing the power supply and the base unit*
 - Preparing the Portable Slit Lamp prior to use*
 - Preparing the patient*
12. Problem solving
13. Changing the bulb
14. Routine instrument maintenance
15. Specifications and electrical ratings
16. Technical specifications
17. Accessories
18. Contact, packaging and disposal information

Please click on the contents to go straight to your chosen section or navigate by using the 'Next' and 'Back' buttons to the right. Clicking on 'Home' will bring you back to this page.

As part of our policy for continued product development we reserve the right to amend specifications at any time without prior notice.

Keeler

[◀ Back](#) [Next ▶](#)

1. Introduction

Thank you for choosing this Keeler product.

Please read this manual carefully before using your rechargeable Keeler Portable Slit Lamp, this will ensure the safety of the patient and ensure you get the best performance from this precision optical device.

Your Keeler Portable Slit Lamp includes:

- Portable Slit Lamp illumination body and magnification optics
- Base charger unit
- Power supply – switch mode all voltages/frequencies (Part 1941-P-7778)
- User instructions and quick guide
- Lens cloth

The information contained within this manual must not be reproduced in whole or part without the manufacturer's prior written approval. The manufacturer reserves the right to make changes to specifications and other information contained in this document without prior notice.

Copyright © Keeler Limited 2009. Published in the UK 2009.



Keeler

Please read and follow these instructions carefully.

[Home](#) [◀ Back](#) [Next ▶](#)

2. Symbols



Read user instructions for Warnings, Cautions and additional information



Double insulated



Type B protections against shock



Consult instructions for use



Manufacturers name and address



This Symbol on the Product or on its Packaging and instructions indicates that it was put on the market place after August 2005 and that this product shall not be treated as Household Waste.



Keep dry



Power input port



Fragile



This way up



Material suitable for recycling

3. Indications for use

Keeler PSL Classic Slit Lamp is an AC-powered Slit lamp biomicroscope is intended for use in eye examination of the anterior eye segment, from the cornea epithelium to the posterior capsule. It is used to aid in the diagnosis of diseases or trauma which affects the structural properties of the anterior eye segment.

This device is intended to be used only by suitably trained and authorised healthcare professionals.

Keeler

4. Intended use / purpose of instrument

The Slit Lamp is an instrument consisting of a light source that can be focused to shine a thin sheet (slit) of light into the eye. It is used in conjunction with a biomicroscope. The lamp facilitates an examination of the anterior segment, or frontal structures and posterior segment, of the human eye, which includes the eyelid, sclera, conjunctiva, iris, natural crystalline lens, and cornea. The binocular Slit Lamp examination provides stereoscopic magnified view of the eye structures in detail, enabling anatomical diagnoses to be made for a variety of eye conditions.

5. Brief description of the instrument

The Keeler Portable Slit Lamp comprises a rechargeable hand held portable illuminated biomicroscope system and a desk mounted base charger unit that is powered from a low voltage (12V) power supply.

The hand held unit incorporates a lithium ion rechargeable battery powering the illumination system. The illumination system and fixation targets are activated using a double click trigger located on the front of the grip/handle. To increase or reduce the light intensity there is a rheostat located below the eyepieces on the rear of the grip /handle.

The 10 x and 16x magnification optical system is controlled using a flip lever located under the adjustable eyepieces.

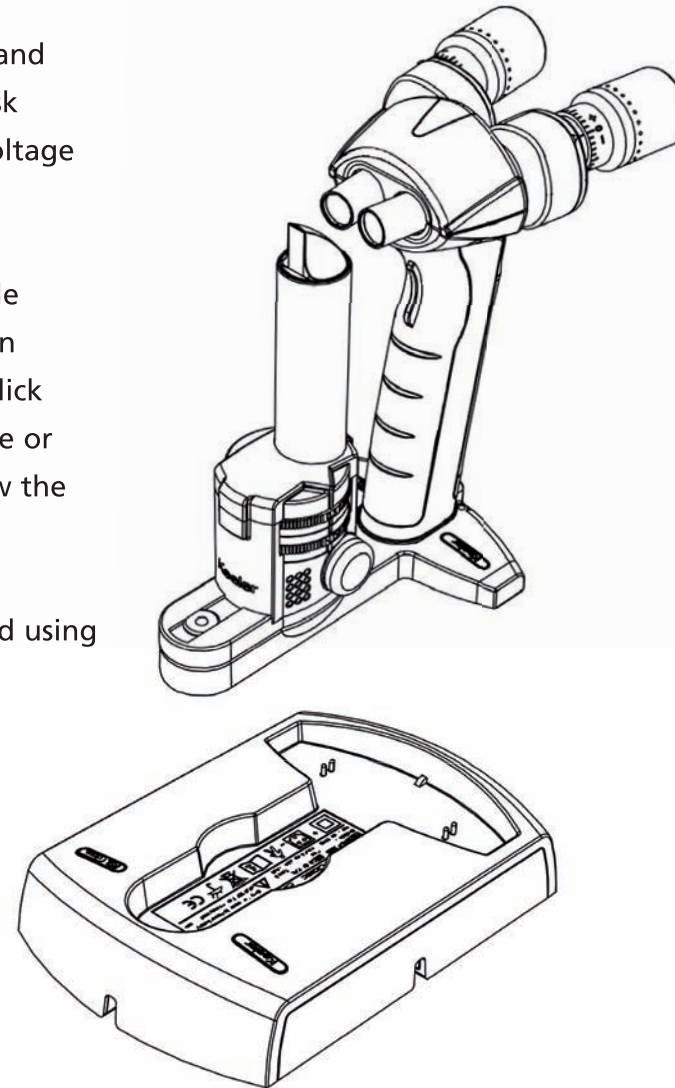

6. Safety

The Keeler Portable Slit Lamp is designed and built in conformity with EC Directive 93/42/EEC and the ISO 9000 and EN 46000 series quality standards.

The  (European Community) mark attests that the Slit Lamp complies with the provisions of Annexes I, VI, and VII of EC Directive 93/42/EEC.

Classification: CE Regulation 93/42 EEC: Class I
FDA: Class II

Production processes, testing, start-up, maintenance, and repairs are conducted in strict conformity with the applicable laws and international reference standards.

Keeler

6. Safety

When using the instrument, scrupulously observe all the relevant accident prevention measures established by law to ensure the safety of the patient.

It is well established that exposure of the eye to intense light sources for extended periods of time poses a risk of retinal photic injury. Many ophthalmic instruments illuminate the eye with intense light. The light levels on the Keeler Slit Lamp is continuously adjustable from maximum to zero. In addition there is an infra red filter incorporated in the illumination system to reduce IR light levels.

No visible retinal lesions have been identified as a result of using Keeler Slit Lamps, however young children and persons with diseased eyes may be at a higher risk. The risk may also be slightly increased if the person being examined has had any exposure with the same instrument or an other ophthalmic instrument using an intense visible light source during the previous 24 hours. This will apply particularly if the eye has been subjected to retinal photography.



Caution. The light emitted from this instrument is potentially hazardous. The longer the duration of exposure, the greater the risk of ocular damage. Exposure to light from this instrument when operated at maximum intensity will exceed the safety guideline after 44 minutes.

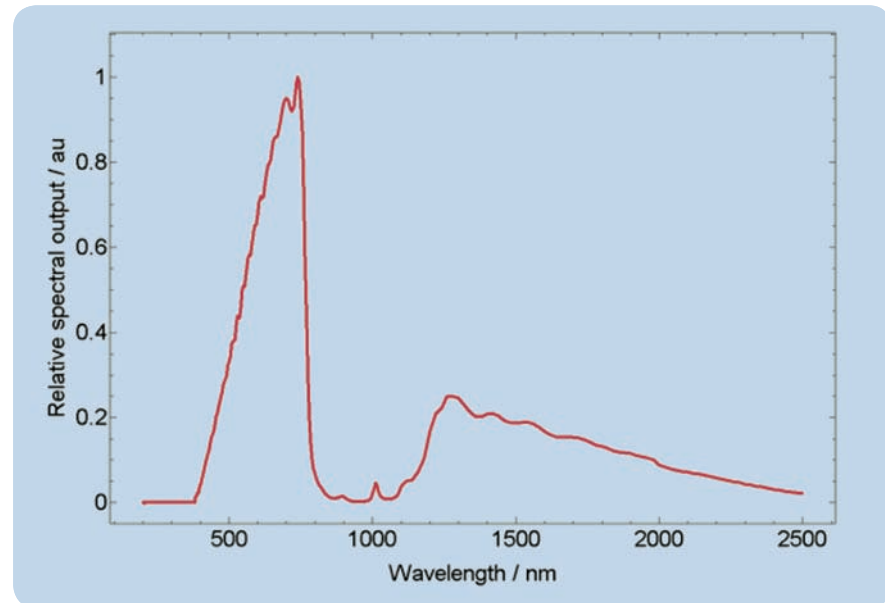

Figure 1: Relative spectral output of PSL Classic

Quantity	Measured Value	Group 2 limit	Pass/Fail Group 2	Comments
E_{ir-cl}	54.82 mW cm ⁻²	100 mW cm ⁻²	Pass	-
L_{A-r}	38.0 mW sr ⁻¹ cm ⁻²	10 J cm ⁻²	Pass with exposure limit	Exposure limit 44 minutes

Keeler

6. Safety

The following statement is provided for US customers and references FDA Slit Lamp Guidance.

Because prolonged intense light exposure can damage the retina, the use of the device for ocular examination should not be unnecessarily prolonged, and the brightness setting should not exceed what is needed to provide clear visualization of the target structures. This device should be used with filters that eliminate UV radiation (< 400 nm) and, whenever possible, filters that eliminate short-wavelength blue light (<420 nm).

The retinal exposure dose for a photochemical hazard is a product of the radiance and the exposure time. If the value of radiance were reduced in half, twice the time would be needed to reach the maximum exposure limit.

While no acute optical radiation hazards have been identified for slit lamps, it is recommended that the intensity of light directed into the patient's eye be limited to the minimum level which is necessary for diagnosis. Infants, aphakes and persons with diseased eyes will be at greater risk. The risk may also be increased if the person being examined has had any exposure with the same instrument or any other ophthalmic instrument using a visible light source during the previous 24 hours. This will apply particularly if the eye has been exposed to retinal photography.

Keeler

7. Cleaning and disinfection instructions

Only manual non-immersion cleaning as described should be used for this instrument. Do not autoclave or immerse in cleaning fluids. Always disconnect power supply from source before cleaning.

- a** Wipe the external surface with a clean absorbent, non-shedding cloth dampened with a water / detergent solution (2% detergent by volume) or water / isopropyl alcohol solution (70% IPA by volume). Avoid optical surfaces.
- b** Ensure that excess solution does not enter the instrument. Use caution to ensure cloth is not saturated with solution.
- c** Surfaces must be carefully hand-dried using a clean non-shedding cloth.
- d** Safely dispose of used cleaning materials.

8. Transport, storage and working conditions

The following ambient condition limits are recommended for the Keeler Portable Slit Lamp, for transport and storage it is recommended that the Slit Lamp is kept in its original manufacturers packaging.

Before use the Slit Lamp should be allowed to adjust to the ambient room temperature for several hours.



This is especially important when the unit has be stored or transported in a cold environment; this can cause severe condensation on the optical elements.

Working environment

+10°C to +35°C

30% to 75% relative humidity

Transport and storage conditions

Transport: -40°C to +70°C

Storage: -10°C to +55°C

Keeler

9. Warnings and cautions

Observe the following prescriptions in order to ensure safe operation of the instrument



- Never use the instrument if visibly damaged and periodically inspect it for signs of damage or misuse.
- Never use the instrument if the ambient temperature, atmospheric pressure, and/or relative humidity are outside the limits given above.
- Before any cleaning of the instrument or the base unit ensure the power lead is disconnected.
- Clean only the exterior surfaces of the instrument following the instructions contained in this manual.
- This product should not be immersed in fluid.
- Repairs and modifications to the instrument must be made only by the specialized technicians of the manufacturer's Technical Service Centre or by personnel trained and authorised by the manufacturer. The manufacturer declines any and all responsibility for loss and/or damages resulting from unauthorised repairs; furthermore, any such actions will invalidate the warranty.
- Should the instrument suffer shocks (for example, should it accidentally fall), and the optical system or the illumination system are damaged it may be necessary to return the instrument to the manufacturer for repair.
- Always carefully observe the safety rules and other precautions published herein.
- This device is intended to be used only by suitably trained and authorised healthcare professionals.
- Federal Law restricts this device to sale by or on the order of a physician or practitioner.
- The owner of the instrument is responsible for training personnel in its correct use.
- Route power cords safely to eliminate risk of tripping or damage to user.
- Ensure the instrument is placed on a level and stable surface.
- Do not use in the presence of flammable gas/liquid.
- The bulb may be hot if the Slit Lamp has been in continuous use, take care when removing the bulb.
- After removal of the bulb, do not touch bulb contacts and patient simultaneously.
- Only use approved Keeler power supply 1941-P-7778 or instrument may malfunction.

Keeler

10. Names of controls and components

Portable Slit Lamp illumination body and magnification optics

- 1. Trigger**
Click and hold the trigger to turn the lamp illumination on. Double click (similarly to a computer mouse button) to turn both the illumination lamp and fixation targets on.
- 2. Prism optical body**
Projects a thin sheet (slit) of light perpendicular to the prism face.
- 3. Eyepieces – dioptical adjustment**
Rotate clockwise to achieve a + (plus) setting and anti-clockwise for a – (minus) setting.
- 4. Eyepieces – PD adjustment**
Rotate the left eyepiece anti-clockwise and the right eyepiece clockwise to increase the PD value. Rotate the left eyepiece clockwise and the right eyepiece anti-clockwise to decrease the PD value.
- 5. Latex free protective sleeves**
These sleeves can be folded forwards to better suit spectacle wearers.
- 6. Fixation targets**
Provides a light source for the patient to focus upon. Double click (similarly to a computer mouse button) to turn both the illumination lamp and fixation targets on.
- 7. Objective lenses**
These lenses are flush with the external surface at a magnification of 10x and protrude from the device at a magnification of 16x.
- 8. Slit wheel**
Rotate the slit wheel to select either a slit of 0.15mm (0.15), 0.5mm (0.5), 0.8mm (0.8), 1.6mm (1.6), a circle of 12mm (O), or a square of 1mm (□) for alc flare assessment. (The text in the brackets corresponds to the icons on the slit wheel.)
- 9. Filter wheel**
Rotate the filter wheel to select either a red free (R.F), blue (B.F), neutral density (N.D) or clear filter (O). (The text in the brackets corresponds to the icons on the filter wheel.)

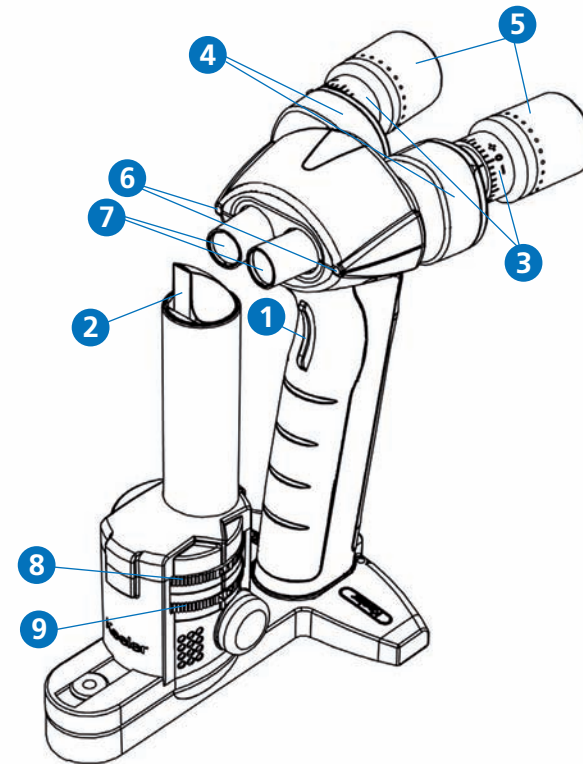

10. Names of controls and components

Portable Slit Lamp illumination body and magnification optics

10. Magnification change lever

Push this lever to the right to set the magnification at 10x and to the left to set the magnification at 16x.

11. Alternative power socket

In addition to charging through the base charger unit, the device can also be charged through this socket.

12. Charging LED

The yellow charging LED is on continuously during normal charging and blinks when trickle charging. Trickle charging can occur at the start of charging a completely discharged battery or when attempting to charge a completely charged battery.

13. Battery state LED

The yellow battery state LED blinks when the battery is almost empty.

14. Brightness adjustment wheel

Rotating this wheel clockwise increases the brightness of the illumination lamp. Rotating this wheel anti-clockwise decreases the brightness of the illumination lamp.

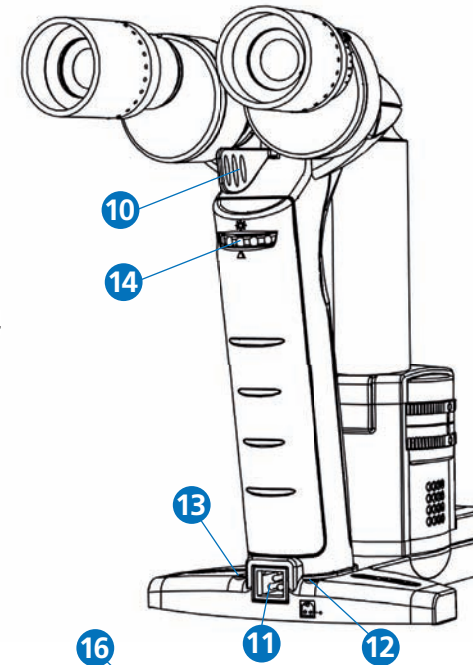

Portable Slit Lamp base charger unit

15. Power socket for Keeler 12V Power Supply

Connect the power supply cable to this socket and then place the slit lamp body in the charger unit to charge the device.

16. Recharging connection pins

Connects the slit lamp body to the charger unit to charge the device.

17. Recess for slit lamp body

Place the slit lamp body in the charger unit when not in use.

18. Grooves for power cable

Place the power supply cable in the most suitable groove to keep the unit tidy.

19. Protective rubber feet

Ensures the surface onto which the charger unit is placed does not become scratched.

20. Charging safety feature

Note: No electrical power is conducted through the pins (16) until the slit lamp body is placed into the recess of the charger unit.

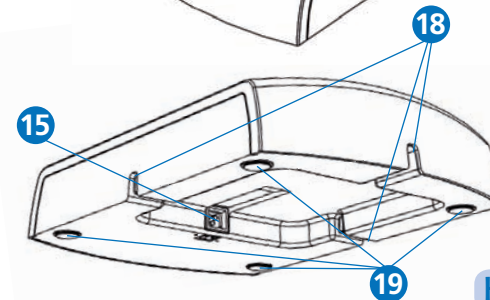
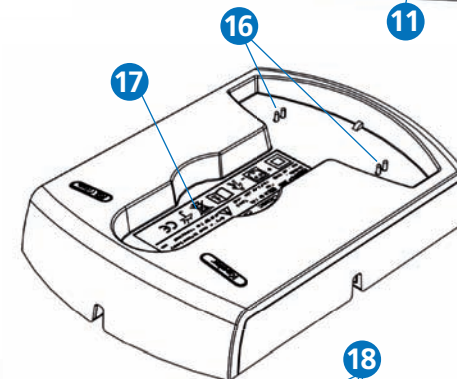

Keeler

11. Instructions for use

Preparing the power supply and the base unit

1. Attach the appropriate mains plug adapter to the transformer after removing the blanking plate or if required use an IEC 60320 type 7 connector (not supplied).
2. Connect the output power supply cable to the socket on the underside of the recharging base unit.

3. Place the Portable Slit Lamp on the base charger unit, the yellow LED will illuminate to indicate the unit is being charged. From fully discharged to fully charged usually takes 2.5 hours.

Illumination 'on time' 50 minutes
(when used at full intensity from fully charged)

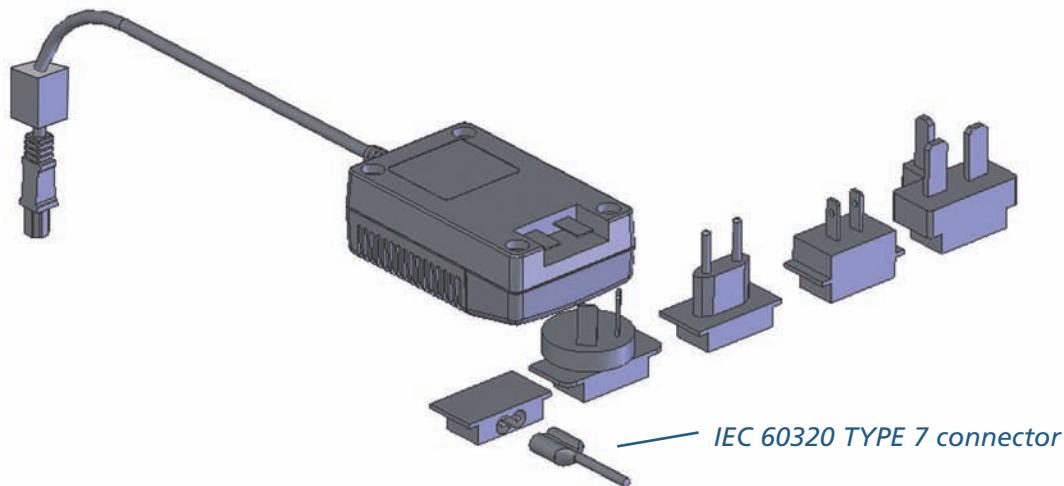

11. Instructions for use

Preparing the Portable Slit Lamp prior to use

1. Set the Pupillary distance of the eyepieces by firmly grasping them and adjusting the distance by gently rotating the prism bodies inwards or outwards until a full circular image is seen binocularly.

2. Adjust the dioptic power of each of the eyepieces, one at a time. Adjust the eyepiece to it's highest + (plus) setting and looking through the optics at the peripheral focus marker, slowly adjust the eyepiece towards the - (minus) setting until the focus marker is sharply in focus. Repeat this for the other eyepiece.

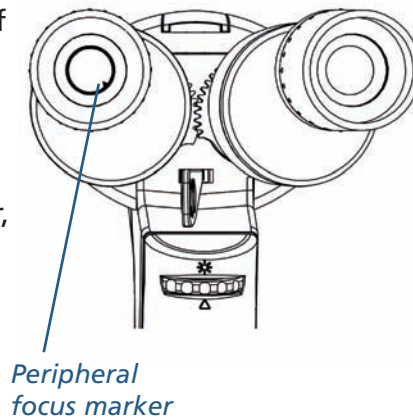

Note – Spectacle wearers may prefer to fold the rubber eye cup forwards.

3. Set the magnification to either x10 or x16 using the magnification change lever.

4. Select your preferred slit width and filter by rotating the slit and the filter wheels.

5. To set the slit at an angle rotate the illumination tower about its pivot axis.

6. Holding the slit lamp firmly click and hold the trigger to turn on the illumination lamp. Double click and hold the trigger to turn on both the illumination lamp and fixation targets. The lamp does not run continuously, after a duration of 2 minutes it automatically switches off.

Note – for very small or young patients, babies in arms and some animals, sometimes it may be preferable to use the Portable Slit Lamp inverted – see illustration.

Note – it can be beneficial to stabilize the Slit Lamp using the technique shown in the illustration below.

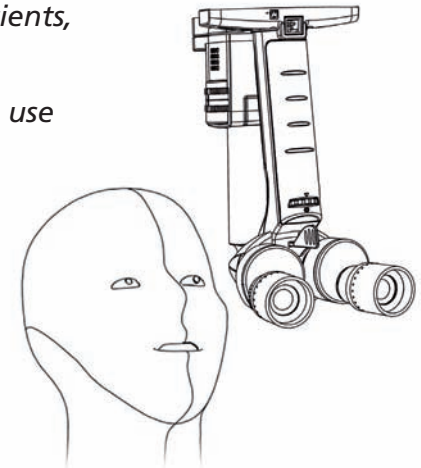

Keeler

11. Instructions for use

Preparing the patient

The patient should be as comfortable as possible and positioned to allow easy access to the eye to be examined.

The Keeler portable Slit Lamp is designed to be ambidextrous, hold the Slit Lamp in your preferred hand simultaneously squeezing the trigger on/off switch.

To improve stability, especially at higher magnifications you may like to use your other hand as a 'bridge' between the Slit Lamp body and the patient.

As with other Slit Lamp examination procedures it may be necessary to elevate the patient's lid.

12. Problem solving

Problem	Solution
No illumination, or low illumination	Check the unit is fully charged
	Check the position of the filters and slits to ensure they are set correctly
	Check and if necessary change the bulb
Slit slanted at an angle	Check the position of the slit disc, it may not be located correctly at a slit position
Circle incomplete or offset	Check the position of the slit and filter discs, it may not be located correctly at a slit position
Poor focus	Check the dioptric settings of the eyepieces

13. Changing the bulb



Warning the bulb may be hot if the Slit Lamp has been in continuous use, take care when removing the bulb.

The bulb has a long life expectancy of approximately 2,000 hours.

Make sure the power is disconnected before changing the bulb. To change the bulb, first allow 5 minutes for it to cool down if the Slit Lamp has been in use.

This is how you change a bulb

1. Unscrew the black plastic bulb cover by turning anti-clockwise.
2. Remove the old bulb, allow 5 minutes for it to cool down if the Slit Lamp has been in use.
3. Insert the new bulb, ensuring the notch is facing upwards as shown.

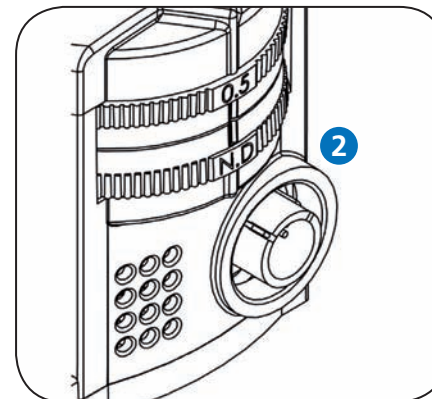
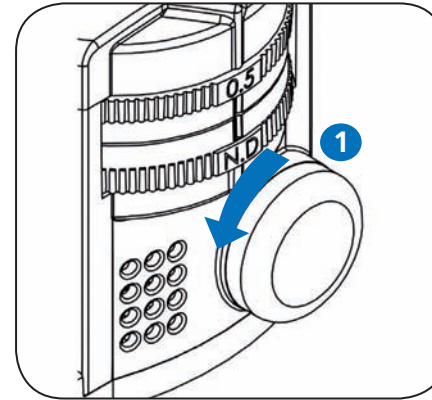
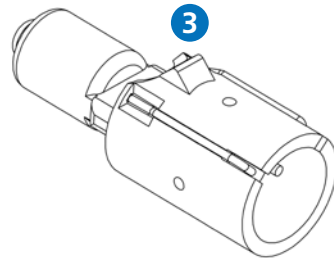

14. Routine instrument maintenance

Regularly inspect the device for damage or dirt.

Care must be taken to keep the objective and the eyepiece lenses clean – use only soft clean lens cloths to clean optical surfaces.

Routinely clean as per section 7. Cleaning instructions.

The manufacturer declines any and all responsibility and warranty coverage should the instrument be tampered with in any manner or should routine maintenance be omitted or performed in manners not in accordance with these manufacturer's instructions.



Caution

Keeler Slit Lamps should be cleaned and serviced regularly. Any servicing or repairs should only be carried out by Keeler Ltd. or by suitably trained and authorised distributors.

There are no user serviceable parts in this instrument. Service manuals will be available to authorised Keeler service centres and Keeler trained service personnel.

Keeler

15. Specifications and electrical ratings

Guidance and manufacturer's declaration – electromagnetic immunity

The Keeler Portable Slit Lamp is intended for use in the electromagnetic environment specified below. The customer or user should assure that it is used in such an environment.

Immunity test	IEC 60601 Test level	Compliance level	Electromagnetic environment - guidance
Electrostatic discharge (ESD). IEC 6100-4-2	± 6 kV contact ± 8 kV air	± 6 kV contact ± 8 kV air	Floors should be wood, concrete or ceramic tile. If floors are covered with synthetic material, the relative humidity should be at least 30%.
Electrical fast transient/burst. IEC 61000-4-4	± 2 kV for power supply lines ± 1 kV for power supply lines	± 2 kV for power supply lines ± 1 kV for input/output lines	Mains power quality should be that of a typical commercial or hospital environment.
Surge. IEC 61000-4-5	± 1 kV line(s) to line(s) ± 1 kV line(s) for input/output line(s)	± 1 kV line(s) to line(s) ± 1 kV line(s) for input/output line(s)	Mains power quality should be that of a typical commercial or hospital environment.
Voltage dips, short interruptions and voltage variations on power supply input lines. IEC 61000-4-11	<5% U_T (> 95% dip in U_T) 40% U_T (60% dip in U_T) for 5 cycles 70% U_T (30% dip in U_T) for 25 cycles <5% U_T (>95% dip in U_T) for 5 s	<5% U_T (> 95% dip in U_T) 40% U_T (60% dip in U_T) for 5 cycles 70% U_T (30% dip in U_T) for 25 cycles <5% U_T (>95% dip in U_T) for 5 s	Mains power quality should be that of a typical commercial or hospital environment. If the user of the Keeler Portable Slit Lamp requires continued operation during power mains interruptions, it is recommended that the instrument be powered from an uninterruptible power supply.
Power frequency (50/60 Hz) magnetic field. IEC 61000-4-8	3 A/m	3A/m	Power frequency magnetic fields should be at a level characteristic of a typical location in a typical commercial or hospital environment.

Note U_T is the a. c. mains voltage prior to application of the test level.

15. Specifications and electrical ratings

The Keeler Portable Slit Lamp is a medical electrical instrument. The instrument requires special care concerning electromagnetic compatibility (EMC). This Section describes its suitability in terms of electromagnetic compatibility of this instrument. When installing or using this instrument, please read carefully and observe what is described here.

1. Portable or mobile-type radio frequency communication units may have an adverse effect on this instrument, resulting in malfunctioning.

Guidance and manufacturer's declaration – electromagnetic emissions		
The Keeler Portable Slit Lamp is intended for use in the electromagnetic environment specified below. The customer or user should assure that it is used in such an environment.		
Emissions test	Compliance	Electromagnetic environment - guidance
RF emissions CISPR 11	Group 1	The Keeler Portable Slit Lamp uses RF energy only for its internal function. Therefore, its RF emissions are very low and are not likely to cause any interference in nearby electronic equipment.
RF emissions CISPR 11	Class A	The Keeler Portable Slit Lamp is suitable for use in all establishments other than domestic and those directly connected to the public low-voltage power supply network that supplies buildings used for domestic purposes.
Harmonic emissions IEC 61000-3-2	Class A	
Voltage fluctuations / flicker emissions IEC 61000-3-3	Complies	

15. Specifications and electrical ratings

Guidance and manufacturer's declaration – electromagnetic immunity

The Keeler Portable Slit Lamp is intended for use in the electromagnetic environment specified below. The customer or user should assure that it is used in such an environment.

Immunity test	IEC 60601 Test level	Compliance level	Electromagnetic environment - guidance
Conducted RF IEC 61000-4-6	3 Vrms	3 V	Portable and mobile RF communications equipment should be used no closer to any part of the Keeler Portable Slit Lamp, including cables, than the recommended separation distances calculated from the equation applicable to the frequency of the transmitter. Recommended separation distance $d = 1.2 \sqrt{p}$
Radiated RF IEC 61000-4-3	3 V/m 80MHz to 2.5GHz	3 V/m	$d = 1.2 \sqrt{p}$ 80MHz to 800 MHz $d = 2.3 \sqrt{p}$ 800MHz to 2.5GHz Where p is the maximum output power rating of the transmitter in watts(W) according to the transmitter manufacturer and d is the recommended separation distance in metres(m). Field strengths from fixed RF transmitters, as determined by an electromagnetic site survey ¹ , should be less than the compliance level in each frequency range. ² Interference may occur in the vicinity of equipment marked with the following symbol: 

Note 1 At 80MHz and 800MHz, the higher frequency range applies.

Note 2 These guide lines may not apply in all situations. Electromagnetic propagation is affected by absorption and reflection from structures, objects and people.

¹ Field strengths from fixed transmitters, such as base stations (cellular / cordless) telephones and land mobile radios, amateur radio, AM and FM radio broadcast and TV broadcast cannot be predicted theoretically with accuracy. To assess the electromagnetic environment due to fixed RF transmitters, an electromagnetic site survey should be considered. If the measured field strength in the location in which the Keeler Portable Slit Lamp is used exceeds the applicable RF compliance level above, the Keeler Portable Slit Lamp should be observed to verify normal operation. If abnormal performance is observed, additional measures may be necessary, such as re-orientating or relocating the Keeler Portable Slit Lamp.

² Over the frequency range 150kHz to 80 MHz, field strengths should be less than 3 V/m.

15. Specifications and electrical ratings

Recommended separation distances between portable and mobile RF communications equipment and the Keeler Portable Slit Lamp

The Keeler Portable Slit Lamp is intended for the use in an electromagnetic environment in which radiated RF disturbances are controlled. The customer or the user of the Keeler Portable Slit Lamp can help prevent electromagnetic interference by maintaining a minimum distance between portable and mobile RF communications equipment (transmitters) and the Keeler Portable Slit Lamp as recommended below, according to the maximum output power of the communications equipment.

Rated maximum output power of transmitter W	Separation distance according to frequency of transmitter m		
	50 kHz to 80MHz	80MHz to 800MHz	800MHz to 2.5GHz
	$d = 1.2\sqrt{p}$	$d = 1.2\sqrt{p}$	$d = 2.3\sqrt{p}$
0.01	0.12	0.12	0.23
0.01	0.37	0.37	0.74
1	1.2	1.2	2.3
10	3.7	3.7	7.4
100	12	12	23

For transmitters rated at a maximum output power not listed above, the recommended separation distance d in metres (m) can be determined using the equation applicable to the frequency of the transmitter, where p is the maximum output power rating of the transmitter in watts (W) according to the transmitter manufacturer.

Note 1 At 80MHz and 800MHz, the separation distance for the higher frequency applies.

Note 2 These guidelines may not apply in all situations. Electromagnetic propagation is affected by absorption and reflection from structures, objects and people.

16. Technical specifications

Biomicroscope

Type	Binocular Hand held Biomicroscope Slit Lamp
Optics	Converging binoculars at 13°
Magnification	10x and 16x, lever change
Objective lens working distance @ 10x	100mm
Objective lens working distance @ 16x	80mm
Field of view @ 10x	16mm
Field of view @ 16x	10.5mm
PD range	50mm to 72mm
Eyepiece dioptric adjustment range	+/- 7 Dioptres
Size:	
Hand held device	238 x 116 x 210 mm
Docking station	205 x 138 x 40 mm
Weight:	
Hand held device	~900g
Docking station	300g

16. Technical specifications

Slit and filter system

Slit type	Rotating Slit wheel selection Slit Lamp
Slit length	12mm
Slit widths	0.15mm, 0.5mm, 0.8mm and 1.6mm slits, 12mm circle and a 1mm square
Filters	Red free, Blue, Neutral density 0.8 and Clear
IR protection	Inbuilt IR cut filter
Slit angle	+/- 60°
Illumination control	Continuously variable from low to full brightness

Power supply

Power supply unit	Switch mode, (110V – 240V) +/- 10% multi plug compliant to EN60601-1 EN 61000-6-2, EN 61000-6-3
Power supply output	30VA (12V DC 2.5A)

Complies with

Electrical Safety (Medical) BS EN 60601-1:2006
Electromagnetic compatibility EN 60601-1-2:2007
Ophthalmic instruments - Fundamental requirements and test methods
ISO 15004-1:2006
Ophthalmic instruments - Optical radiation hazard ISO 15004-2:2007

Keeler

17. Accessories

Accessories

Aluminium Carry Case	Part Number 3010-P-7000
Test Bar	Part Number EP39-70737
Power Supply	Part Number 1941-P-7778
2x Rubber Eye Caps	Part Number 3010-P-7004

Consumables

Slit Lamp 6V 15W Bulb	Part Number 1030-P-7187
-----------------------	-------------------------

18. Contact, packaging and disposal Information

Manufacturer

Keeler Limited
Clewer Hill Road
Windsor
Berkshire
SL4 4AA

Freephone: 0800 521251
Tel: +44 (0) 1753 857177
Fax: +44 (0) 1753 827145

USA Sales Office

Keeler USA
456 Parkway
Broomall
PA 19008
USA

Toll Free: 1 800 523 5620
Tel: 1 610 353 4350
Fax: 1 610 353 7814

Disposal of old Electrical and Electronic Equipment

(Applicable in the European Union and other European Countries with separate Collection Systems).



This Symbol on the Product or on its Packaging and instructions indicates that it was put on the market place after August 2005 and that this product shall not be treated as Household Waste.

To Reduce the Environmental impact of WEEE (Waste Electrical Electronic Equipment) and minimise the volume of WEEE entering landfills we encourage at Product end of life that this Equipment is recycled and reused.

If you need more information on the collection reuse and recycling then please contact B2B Compliance on 01691 676124 (+44 1691 676124).

 3010-P-7001 Issue G

